

PRODUCT BASIC INFORMATION

VMH 35-D

Best Performances in Outdoor Environments



VMH 35-D

Stylish black glass cockpit design / slim panel profile / powerful core

KEY FEATURES

- ▶ 12/24 V operating voltage
- ▶ SAE J1939 CAN port
- ▶ High-performance GPS embedded
- ▶ More than 30 data displayed
- ▶ 4x analog input for external sensors
- ▶ EasyLink output for up to 16 VMH 14 satellites
- ▶ Analog/CAN to NMEA 2000® gateway



The **VMH 35-D** is the perfect standalone solution for monitoring your diesel engine. With a configurable dial scale of 3000 or 4000 RPM, the VMH 35-D is a compact display capable of showing a wide amount of data from your engine, battery, tank, and GPS.

Specific information about your diesel engine is provided together with alarms, either received from the SAE J1939 bus or locally set through the embedded menu. Both 12V and 24V systems are supported, as well as EasyLink connectivity which allows your dashboard to be expanded with additional **VMH 14** satellite displays to always keep your sensitive data under control. The embedded high-performance GPS receiver further enhances the display capabilities by adding speed, position and heading data.



Setup local alarms and send them to other devices via NMEA 2000®



The finest quality in every detail



Water-sealed connector and NMEA 2000® DeviceNet plug

GPS DATA

Navigation system	GPS, GLONASS, Galileo
Update rate	10 Hz
Channels	72
Tracking sensitivity	-165 dBm
Time to first fix (hot start)	1 s
Time to first fix (cold start)	30 s
Position accuracy	2.5 m
Velocity accuracy	0.05 m/s
Heading accuracy	0.3°

TECHNICAL DATA

Operating voltage	12 V / 24 V
Voltage range	9 - 32 V
Protection class	IP X7
Flammability	UL94 compliant
Power consumption	≤ 170 mA (normal mode) ≤ 120 µA (sleep mode)
Dimensions	Ø 100 (Ø 85 mm mounting)
Active area	Ø 83 mm (optically bonded display)
Central display	1.44", 128 x 128 Pixel
Lens	Mineral glass
Buttons	2 silicon buttons
Ring	Brushed stainless steel
Operating temperature	-20°C to 60°C
Storage temperature	-30°C to 80°C
Plugs	Molex MX-150, 12 pins DeviceNet M12, 5 pins



**Best performances
in outdoor environments**





Monitoring your diesel engine has never been that easy

TFT DISPLAYED DATA

Freshwater Level	Coolant Pressure
Wastewater Level	Engine Oil Temperature
Rudder Angle	Engine Oil Pressure
Trim	Boost Pressure
GPS Position	Ammeter
Course Over Ground	Battery Voltage
Engine Speed (RPM)	Battery State of Charge
Seawater Temperature	Battery State of Health
Depth	Battery Autonomy
Clock	Battery Temperature
Hour Counter (Total+Trip)	AdBlue Level
Trip Distance	Air Intake Temperature
Total Fuel Used	Engine Load
Fuel Consumption	Exhaust Gas Temperature
Fuel Level	Transmission Oil Temperature
Coolant Temperature	Transmission Oil Pressure

ADDITIONAL DISPLAYED DATA

✓ Engine Speed	✓ Gear position
✓ Boat Speed (SOG or STW)	✓ 6x Alarm telltales



DIMENSIONS

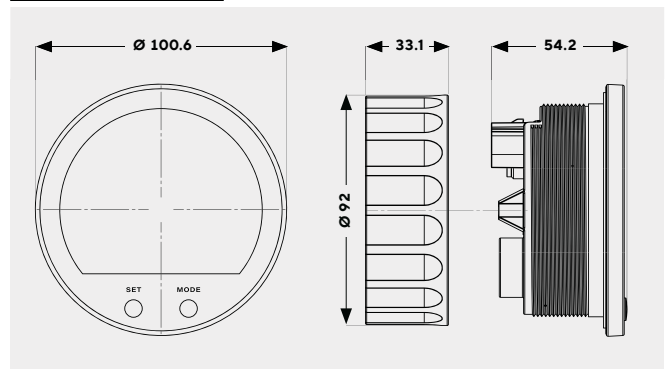

NMEA PGNS

System Time	126992	Engine Parameters, Dynamic	127489	Battery Status	127508
Rudder	127245	Fluid Level	127505	COG and SOG, Rapid Update	129026
Engine Parameters, Rapid Update	127488	DC Detailed Status	127506	GNSS Position Data	129029
Speed - Water referenced	128259	Water depth	128267	Position, Rapid Update	129025
Local Time Offset	129033	Temperature	130316	Transmission Parameters, Dynamic	127493

» **STYLISH DESIGN AND POWERFUL CORE**



ART. NR. B00109901

VMH 14



- ▶ VMH look-and-feel
- ▶ Digital display with visual bargraph
- ▶ Easylink interface
- ▶ Up to 16 satellites
- ▶ Configurable with your smartphone via Airlink
- ▶ Trim, Voltmeter, Fuel Level, Water Temperature, Transmission Oil Temp. and Pressure, Engine Oil Temp. and Pressure