

Keep this
manual onboard!



User Manual

For Thruster Models
DC SEP & SEP-IP Electric



SLEIPNER AS

P.O. Box 519

N-1612 Fredrikstad

Norway

www.sleipnergroup.com

DOCUMENT ID: 5916

REVISION: II

DATE: 2022

LANGUAGE: EN

U
M

To download your language go to www.sleipnergroup.com

Contents

User Manual

Responsibility of the user operating thrusters	3
General user considerations and precautions for electric thrusters	3
General user considerations and precautions for DC electric motors	3
General user considerations and precautions for IP systems	3
User operation	4
Compatible control device products	4
Proportional control panel	5
Maintenance	6 - 8
Basic troubleshooting	9
Advanced troubleshooting	9
Seasonal checklist	10
Service and Support	11
Product Spare Parts and Additional Resources	11
Warranty Statement	11

Products

SEP300/300TC - SEP300 tunnel thruster 48v
SEP250/300TC - SEP250 Tunnel thruster, 24v
SEP210/250TC - SEP210 Tunnel thruster, 24V
SEP170/250TC - SEP170 Tunnel thruster, 24V
SEP150/215T-24V - SEP150 Tunnel thruster, 24V
SEP130/250T-24V - SEP130 Tunnel thruster, 24V
SEP130/250T-12V - SEP130 Tunnel thruster, 12V
SEP120/215T-24V - SEP120 Tunnel thruster, 24V
SEP100/185T-12V - SEP100 Tunnel thruster, 12V
SEP100/185T-24V - SEP100 Tunnel thruster, 24V
SEP80/185T-12V - SEP80 Tunnel thruster, 12V
SEP80/185T-24V - SEP80 Tunnel thruster, 24V
SEP60/185S-12V - SEP60 Tunnel thruster, 12V
SEP60/185S-24V - SEP60 Tunnel thruster, 24v
SEP60/185S2-12V - SEP60 Tunnel thruster, 12v
SEP60/185S2-24V - SEP60 Tunnel thruster, 24v
SEP50/140S-12V - SEP50 Tunnel thruster, 12v
SEP50/140S-24V - SEP50 Tunnel thruster, 24v
SEP40/125S2 - SEP40 Tunnel thruster, 12v
SEP40/125S - SEP40 Tunnel thruster, 12V
SEP30/125S2 - SEP30 Tunnel thruster, 12v
SEP30/125S - SEP30 Tunnel thruster, 12v
SEP25/110S - SEP25 Tunnel thruster, 12v
SEP170/250TC-IP - SEP170 Tunnel thruster, 24V-IP
SEP130/250T-12IP - SEP130 Tunnel thruster, 12V-IP
SEP130/250T-24IP - SEP130 Tunnel thruster, 24v
SEP120/215T-24IP - SEP120 Tunnel thruster, 24V-IP
SEP100/185T-24IP - SEP100 Tunnel thruster, 24V-IP
SEP100/185T-12IP - SEP100 Tunnel thruster, 12V-IP
SEP80/185T-12IP - SEP80 Tunnel thruster, 12V-IP
SEP80/185T-24IP - SEP80 Tunnel thruster, 24v-IP
SEP60/185S2-12IP - SEP60 Tunnel thruster, 12v-IP
SEP60/185S-12IP - SEP60 Tunnel thruster, 12V-IP
SEP50/140S-24IP - SEP50 Tunnel thruster, 24v-IP
SEP50/140S-12IP - SEP50 Tunnel thruster, 12v-IP
SEP40/125S2-IP - SEP40 Tunnel thruster, 12v-IP
SEP40/125S-IP - SEP40 Tunnel thruster, 12V-IP



Sleipner Motor AS
P.O. Box 519, Arne Svendsensgt. 6-8
N-1612 Fredrikstad, Norway

MC_0020

Failure to follow the considerations and precautions can cause serious injury, damage and will render all warranties given by Sleipner Motor as VOID.

MC_0411

General Operation Considerations and Precautions Guidelines

MC_0444

For the operation of thrusters

MC_0418

Never use thrusters when close to objects, persons or animals in the water. The thruster will draw objects into the tunnel and the rotating propellers. This will cause serious injuries and damage the thruster.

Always turn the main power switch off before touching any part of the thruster. An incidental start while touching moving parts can cause serious injuries.

It is the owner, captains or other responsible parties full responsibility to assess the risk of any unexpected incidents on the vessel. If the thruster stops giving thrust for some reason while manoeuvring you must have considered a plan on how to avoid damage to persons or other objects.

- Always turn the control device off when the thruster is not in use or when leaving the boat.
- When leaving the boat always turn off the main power switch for the thruster.
- Never use thrusters out of water.
- If the thruster stops giving thrust while running, there is possibly a problem in the drive system. You must immediately stop running the thruster and turn it off. Running the thruster for more than a few seconds without resistance from the propeller can cause serious damage to the thruster.
- If two panels are operated with conflicting directions at the same time the thruster will not run. If both are operated in the same direction, the thruster will run in this direction.
- If you notice any faults with the thruster switch it off to avoid further damage.
- The primary purpose of the thruster is to manoeuvre or dock the vessel. Forward or reverse speed must not exceed 4 knots when operated.

For the operation of electric thrusters

MC_0004

Never store items (e.g. equipment, sails, ropes etc.) in the same compartment as the thruster. When the thruster runs for an extended period, it can reach 150°C and will cause damage to nearby items or cause a fire.

Any loose items near the thruster motor can cause problems with electrical wiring coming loose and short-circuiting.

- Ensure you know the location of the main battery switch that disconnects the thruster from all power sources (batteries) so the thruster can be turned off in case of serious malfunction.
- We advise keeping the main engine(s) running while using the thruster. This will keep the batteries in a good charge condition. It will also give better performance to the thruster.
- If the performance of the thruster is reduced check the battery system or check the tunnel for marine growth.
- The electric motor, its components, contacts/ plugs or other joints in the control cables must be mounted so they will remain dry at all times.

For the operation of DC electric motors

MC_0419

- The DC electric motor will generate some carbon dust during operation. Ensure any storage compartments are separated from the thruster area to prevent nearby items from becoming dusty.
- The maximum continuous run time of the electrical thruster is approximately 3 minutes. The electrical motor includes a built-in thermal cut off switch that will shut down the motor when it detects overheating. Consider this when planning your manoeuvring.

NEVER Disassemble any part of the Ignition Protected assembly. Tampering with the Ignition Protected assembly will cause it to lose this safety feature. If there is a problem with your Ignition Protected motor, please contact your dealer.

MC_0007

! Please refer to the graphic for special considerations relating to your model !

The following is an operation guide to ALL Sleipner control products. Ensure to familiarise yourself with the functionality and operation of your specific control device.

Take time to practice operation in open water to become familiar with the thruster and to avoid damages to your boat or people.

General operation

1. Turn on the main power switch for the bow thruster. *(NB: Always turn off the main power switch when not on-board.)*
2. Turn on the control panel by pushing the/ both "ON" button(s) on the original Sleipner panel simultaneously.
*Turn off the control panel by pushing the "OFF" button
3. To Turn the bow/ stern in the desired direction:

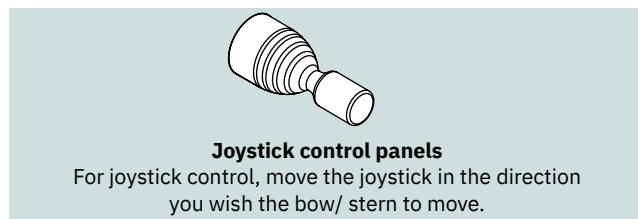
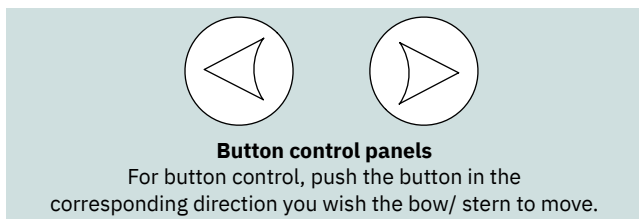

(NB: If equipped for proportional control move the joystick equivalent to the amount of thrust you intend to receive.)

* For other controls like foot switches or toggle-switches please refer to that products user manual for detailed operational use.

Hold functionality

If equipped with 'hold' functionality push the button in the corresponding direction you wish the thrusters to engage a holding pattern:

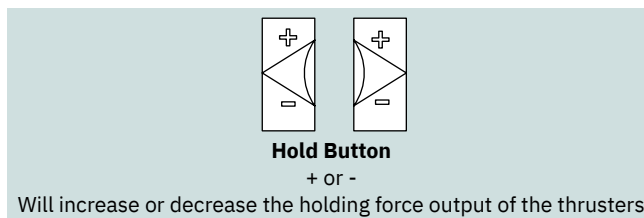

Operating a combined bow and stern thruster

The combination of a bow and stern thruster offers total manoeuvrability to move the bow and the stern separately from each other or in unison. This enables the boat to move sideways in both directions or turn the boat around a 360° axis while staying stationary.

Remote controls

Ensure the remote control is held in the same direction as the boat during operation.

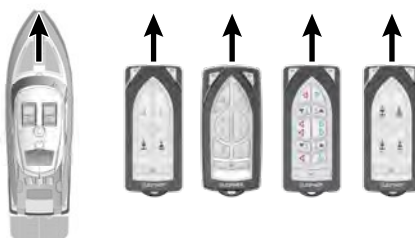

Drift

Depending on the sideways speed of the bow/ stern, you must disengage the control device shortly before the vessel is in the desired position.

(NB: Be aware the boat will continue to move after disengaging the thruster control.)

At any significant cruising speed (+1-2 kn) the side thruster will have little effect to steer the vessel.

Compatible Control Device Products

! Please refer to the graphic for special considerations relating to your model !

PRO proportional CONTROL PANEL



PJC211

PJC212

S-Link REMOTE CONTROL



RCS-20

For additional information refer to your control device manual



Proportional Control Panel

Activating the bow thruster



Activating the stern thruster



Activating both bow and stern thruster to push the boat sideways

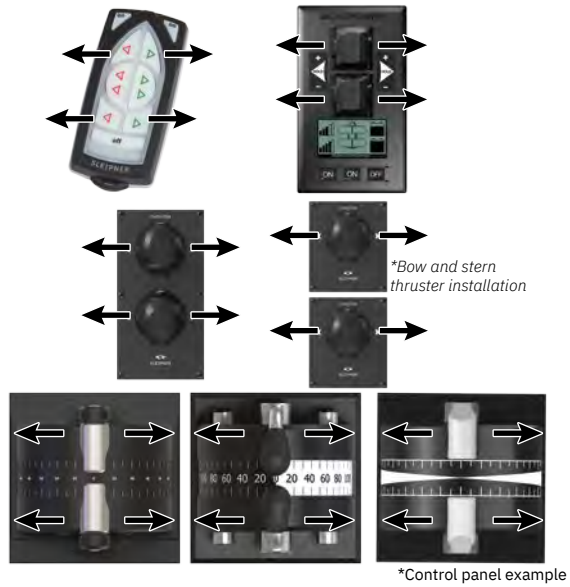

Activating both bow and stern thruster to rotate the boat on axis

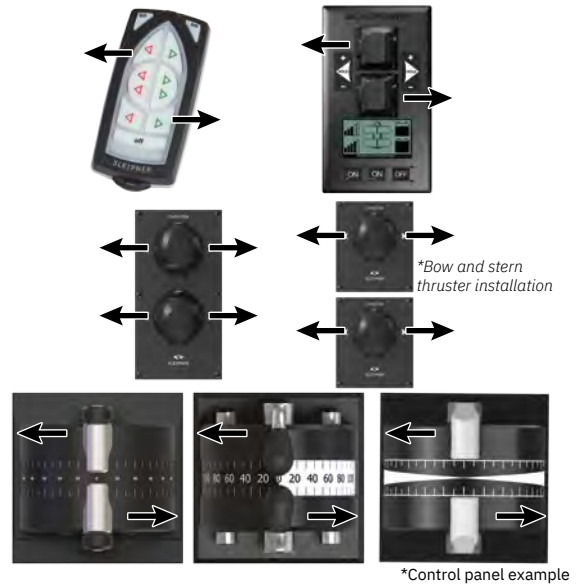

As a part of the seasonal service of your Thruster before every season, always check that:

In Water

- The area around the thruster inside the boat is clean and dry. Ensure there are no signs of water leaks.
- All electrical connections are clean and fastened firmly.
- Ensure that your batteries are in good condition.

Out of Water

- Check the propeller(s) or tunnel for any damage for example impact damage.
- The propeller(s) is fastened securely to the gear leg.
- Check all components of thruster are fastened securely.
- Clean the tunnel and gear leg from marine growth.
- Paint the propeller and gear leg with anti-fouling before every season to keep it clean from sea growth. **(NB: Never paint the anode, sealing or propeller shaft. Ensure paint does not enter the space between the propeller and the gear leg.)**
- Change the anode before every season, or when half the anode has eroded. Always use a sealant or thread glue on the holding screw to ensure that it does not fall off.
- Check the gear leg is not leaking oil

NEVER Disassemble any part of the Ignition Protected assembly. Tampering with the Ignition Protected assembly will cause it to lose this safety feature. If there is a problem with your Ignition Protected motor, please contact your dealer.

MC_0007

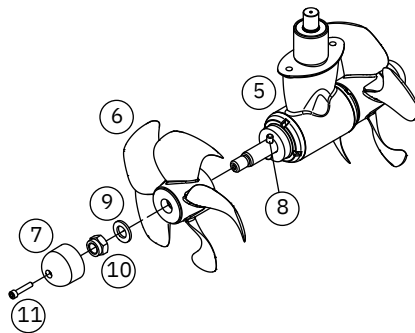
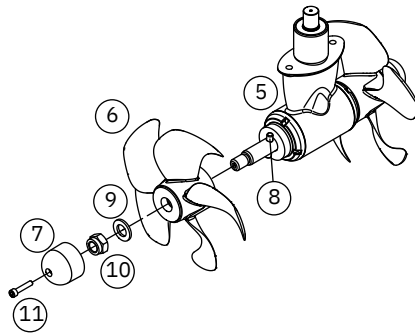
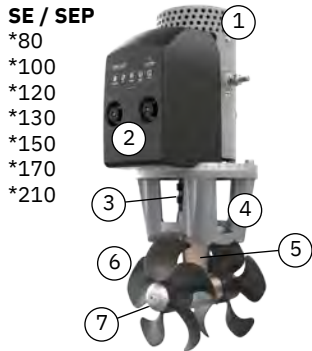
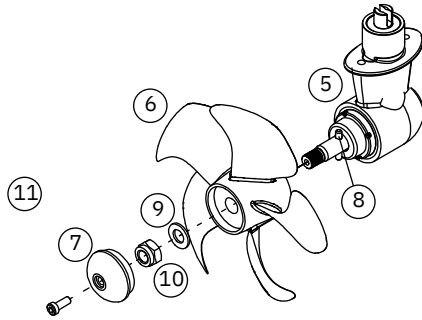
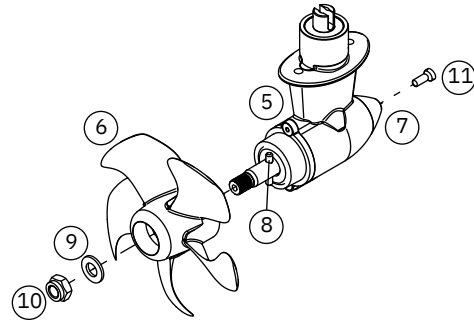
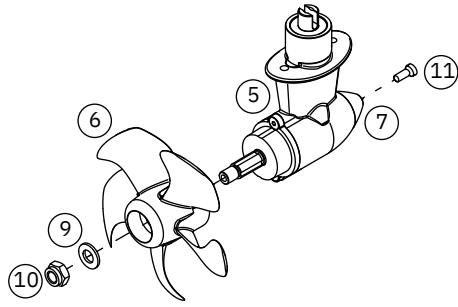

KEY:

- 1. Electro motor
- 2. Directional Solenoids/ power & control cables
- 3. Coupling (inside motor bracket)
- 4. Motor Bracket
- 5. Gear Leg
- 6. Propeller
- 7. Anode
- 8. Propeller Drive pin
- 9. Washer
- 10. Lock Nut
- 11. Fastening Screw for anode

SE / SEP (IP)
*30
*40

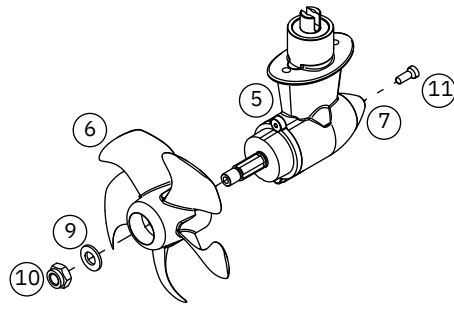

SE / SEP (IP)
*50

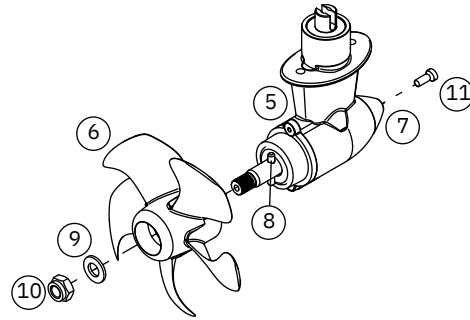

SE / SEP (IP)
*60

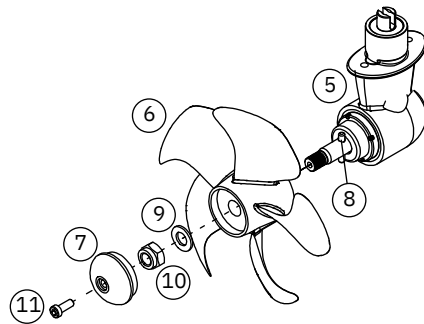

SE / SEP (IP)
*80
*100
*120
*130
*170

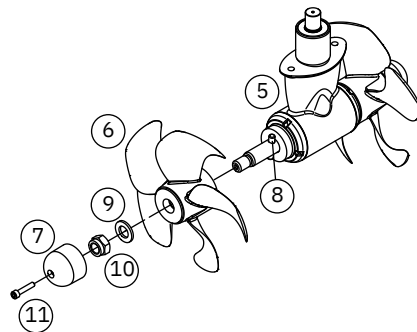

KEY:

- 1. Electro motor
- 2. Directional Solenoids/ power & control cables
- 3. Coupling (inside motor bracket)
- 4. Motor Bracket
- 5. Gear Leg
- 6. Propeller
- 7. Anode
- 8. Propeller Drive pin
- 9. Washer
- 10. Lock Nut
- 11. Fastening Screw for anode

Before seeking assistance from the website help desk from your Sleipner dealer/ distributor, please perform these tests.
(NB: If you are unable to understand or perform these checks, you must consult a Sleipner distributor.)

CHECK	SOLUTION
The motor runs, but there is no thrust	
Check propellers are fitted, fastened correctly and there is no damage to the prop shaft.	Re-fasten or replace if necessary
* Check the flexible coupling between the motor and drive shaft is fitted correctly and not damaged.	Replace if necessary
* Check the gear leg is not damaged.	Replace if necessary
The thrusters performance is reduced	
Check the propeller, gear house and tunnel are free from growth/ barnacles or debris and damage.	Remove growth and clean. (NB: If there is obstruction in the tunnel it will disturb/ block the water flow and significantly reduce performance.)
Check the battery is in a good working condition.	(NB: Keep the main engine(s) running in use to have a continuous charge to the batteries) <ul style="list-style-type: none"> • Check batteries are not worn out or in a bad charged condition • Check electrical connections/ wiring for damage or wear (corrosion) • Check cables are the correct size per the product manual • Tighten/ re-adjust connections
The thruster does not start/ works in only one direction or does not turn off	
Check the main switch is active/ on.	Open the main switch if it is closed.
Check all battery fuses are in good condition.	<ul style="list-style-type: none"> • Check batteries • Check electrical connections/ wiring for damage or wear (corrosion) • Tighten/ re-adjust and clean connections <div style="text-align: right; margin-top: -10px;">} Replace if necessary</div>
The thruster is not shutting off after the Joy Stick/ panel is disengaged.	Hit the main switch to disengage the thruster. Contact and consult a Sleipner distributor as the control system has been damaged.
The thruster works in only one direction	
Damaged relay.	Hit the main switch to disengage the thruster. Contact and consult a Sleipner distributor as the control system has been damaged.
The thruster runs in a pulsing action	
This is a build-in error response. -Solenoids failure	Hit the main switch to disengage the thruster. Contact and consult a Sleipner distributor.
The solenoid might be in a lock-in/ auto stop position.	Hit the main switch to disengage the thruster. Contact and consult a Sleipner distributor.

* Not applicable to SX thrusters.

Advanced Control Panel Troubleshooting

Control panels operating on the S-link system display all faults via the control panel interface or via other warning methods.

To review any issues of your product refer to the appropriate user manual for a complete list of fault codes and troubleshooting guides.

For additional supporting documentation, we advise you to visit our website www.sleipnergrouper.com



CHECK TO PERFORM	DATE												
The propeller is fastened securely to the gear leg.													
The thruster components are fastened securely.													
The area around the thruster is clean and dry. If there are signs of water, try to find the source and eliminate it.													
Apply the propeller and gear leg with anti-fouling.													
Batteries are in good condition.													
All electrical connections are clean and fastened firmly.													
Replace the anode.													

Find your local professional dealer from our certified worldwide network for expert service and support.

visit our website www.sleipnergrou.com/support

Product Spare Parts and Additional Resources

For additional supporting documentation, we advise you to visit our website www.sleipnergrou.com and find your Sleipner product.

Warranty statement

1. Sleipner Motor AS (The “Warrantor”) warrants that the equipment (parts, materials and embedded software of products) manufactured by the Warrantor is free from defects in workmanship and materials for the purpose for which the equipment is intended and under normal use and service (the “Warranty”).
2. This Warranty is in effect for two years (Leisure Use) or one year (Commercial and other Non-leisure Use) from the date of purchase by the end user (for demonstration vessels, the dealer is deemed as end user).
3. This Warranty is transferable and covers the equipment for the specified warranty period.
4. The warranty does not apply to defects or damages caused by faulty installation or hook-up, abuse or misuse of the equipment including exposure to excessive heat, salt or fresh water spray, or water immersion except for equipment specifically designed as waterproof.
5. In case the equipment seems to be defective, the warranty holder (the “Claimant”) must do the following to make a claim:
 - (a) Contact the dealer or service centre where the equipment was purchased and make the claim. Alternatively, the Claimant can make the claim to a dealer or service centre found at www.sleipnergrou.com. The Claimant must present a detailed written statement of the nature and circumstances of the defect, to the best of the Claimant’s knowledge, including product identification and serial nbr., the date and place of purchase and the name and address of the installer. Proof of purchase date should be included with the claim, to verify that the warranty period has not expired;
 - (b) Make the equipment available for troubleshooting and repair, with direct and workable access, including dismantling of furnishings or similar, if any, either at the premises of the Warrantor or an authorised service representative approved by the Warrantor. Equipment can only be returned to the Warrantor or an authorised service representative for repair following a pre-approval by the Warrantor’s Help Desk and if so, with the Return Authorisation Number visible postage/shipping prepaid and at the expense of the Claimant.
6. Examination and handling of the warranty claim:
 - (a) If upon the Warrantor’s or authorised service Representative’s examination, the defect is determined to result from defective material or workmanship in the warranty period, the equipment will be repaired or replaced at the Warrantor’s option without charge, and returned to the Purchaser at the Warrantor’s expense. If, on the other hand, the claim is determined to result from circumstances such as described in section 4 above or a result of wear and tear exceeding that for which the equipment is intended (e.g. commercial use of equipment intended for leisure use), the costs for the troubleshooting and repair shall be borne by the Claimant;
 - (b) No refund of the purchase price will be granted to the Claimant, unless the Warrantor is unable to remedy the defect after having a reasonable number of opportunities to do so. In the event that attempts to remedy the defect have failed, the Claimant may claim a refund of the purchase price, provided that the Claimant submits a statement in writing from a professional boating equipment supplier that the installation instructions of the Installation and Operation Manual have been complied with and that the defect remains.
7. Warranty service shall be performed only by the Warrantor, or an authorised service representative, and any attempt to remedy the defect by anyone else shall render this warranty void.
8. No other warranty is given beyond those described above, implied or otherwise, including any implied warranty of merchantability, fitness for a particular purpose other than the purpose for which the equipment is intended, and any other obligations on the part of the Warrantor or its employees and representatives.
9. There shall be no responsibility or liability whatsoever on the part of the Warrantor or its employees and representatives based on this Warranty for injury to any person or persons, or damage to property, loss of income or profit, or any other incidental, consequential or resulting damage or cost claimed to have been incurred through the use or sale of the equipment, including any possible failure or malfunction of the equipment or damages arising from collision with other vessels or objects.
10. This warranty gives you specific legal rights, and you may also have other rights which vary from country to country.

Patents

At Sleipner we continually invest to develop and offer the latest technology in marine advancements. To see the many unique designs we have patented visit our website www.sleipnergrou.com/patents

© **Sleipner Group**, All rights reserved
The information given in the document
was right at the time it was published.
However, Sleipner Group cannot
accept liability for any inaccuracies or
omissions it may contain. Continuous
product improvement may change the
product specifications without notice.
Therefore, Sleipner Group cannot accept
liability for any possible differences
between product and document.

**Register your product and learn more
at www.sleipnergroun.com**



SLEIPNER AS

P.O. Box 519

N-1612 Fredrikstad

Norway

www.sleipnergroun.com

Made in Norway

